

IN2000/800
Federico Rossi

ABSTRACT

A new active system for reduction of rolling noise produced by tyre-ground contact is proposed (patent n.01297959) [1]. The system is constituted by acoustical emitters installed on the car mudguard close to tyre-ground point of contact. Acoustical emitters are fed by an electronic control unit which generates the control signal according to an error minimization technique. Acoustical emitter performances have been tested by means of an original experimental facility built at Acoustic Laboratory of the University of Perugia. Such a facility allows to optimize the acoustical performances of the active noise control system by simulating rolling noise on steady conditions. Active noise control emitter has been modeled by means of electrical equivalent circuit method; thus transfer function has been attained.

1-INTRODUCTION

Terrestrial vehicles noise is due to four different causes: 1) exhaust duct emission; 2) aerodynamic friction; 3) mechanical structures vibrations; 4) rolling of tyres on ground. The contribute of the fourth cause may be predominant in the 50-150 Km/h vehicle speed range[2]. Till now rolling noise has been moderately attenuated by means of an appropriate design of tyre contact surface shape. An active noise control system for a strong attenuation of rolling noise is proposed (patent n.01297959) [1]. Such a system is made up by a peculiar acoustical emitter which is to be installed on a vehicle mudguard. The emitter is driven by a control unit whose input data are tyre r.p.s. and an error signal picked up by a microphone. This paper deals with an original experimental facility which simulates rolling noise emission. The facility allows to test the rolling noise control system on different working conditions.

2-ROLLING NOISE ACTIVE CONTROL SYSTEM

Rolling noise is produced at tyre-ground point of contact. Acoustical emission is due to air compression (rarefaction) which occurs when the tyre superposes (gives up) the ground. Thus rolling noise is the sum of a compression and a dilatation noise. The rolling noise spectrum and power depends on tyre r.p.s. and tyre surface shape [2]. The active control system proposed for rolling noise attenuation is sketched in Fig.1. Such a system is composed by the following elements: A) two acoustical emitters, B) control unit, C) r.p.s. pick up, D) two error microphones, E) two power amplifiers. As shown in Fig.2, each acoustical emitter is constituted by a variable section duct which terminates with an outlet mouth.

A loudspeaker is installed inside the acoustical emitter at the top of the duct; thus loudspeaker sound waves propagate through the duct till the outlet mouth. On the rear side of the loudspeaker a coverage is installed which creates a rear air volume [3]. Rear air volume is connected to the propagation duct by two 10mm ϕ holes in order to increase the loudspeaker low frequency performances. Each acoustical emitter INOX walls thickness is 3mm; such a property determines very low wall acoustical transmission [4]. The acoustical emitter shape fits a common

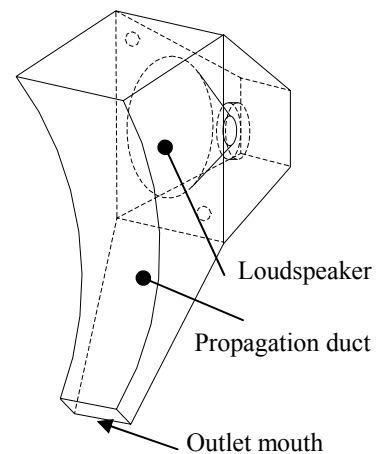
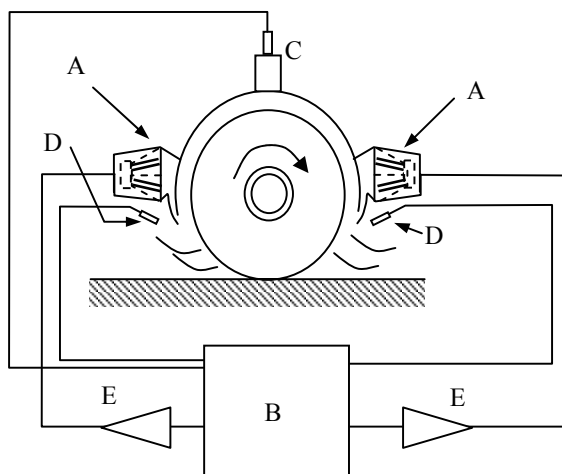

vehicle mudguard shape in order to provide a vehicle installation. The control unit core is a DSP which processes input signals in order to get two control signals respectively for air compression and dilatation noise. The control signal amplitude is proportional, but opposite, to the rolling noise one. Input signals are tyre r.p.s. and two error signals; the first one is got by means of an optical encoder installed on the tyre hub, the second and the third ones are got by means of two microphones installed as shown in fig.1. The amplifier is fed by the two control signals in order to drive the two acoustical emitters with an adequate power. The rolling noise interferes with the equal amplitude, but opposite sign, control signal in the space which separates the tyre-ground point of contact and the acoustical emitter outlet mouth; the result is a reduction of global noise.

Fig. 1: Rolling noise active control system

Fig. 2: Active control system acoustical emitter.

3-THE EXPERIMENTAL FACILITY

Calibration, optimization and testing of rolling noise active control system are very difficult on running vehicle conditions. Thus an experimental facility has been set up which simulates the rolling noise phenomena on steady condition. Such experimental facility, as shown in fig.3, is

made up by the following elements: D.A.T. recorder, power loudspeaker; acoustical impedance adaptation duct, tyre-ground contact emitter, tyre, flat plate covered by asphalt like film, adjustable frame. The D.A.T. reproduces a previously recorded rolling noise (both air compression and air rarefaction noise may be reproduced); D.A.T. output is plugged in the power loudspeaker which emits sound waves inside the acoustical impedance adaptation duct. The power loudspeaker is insulated from the external environment by a coverage box. The shape of the acoustical impedance adaptation duct is cone like whose terminal section is connected to the tyre-ground contact emitter; such an element is a particular shape duct whose terminal section lies on the flat plate covered by asphalt like film (see fig.3). A common vehicle tyre lies on the flat plate; the tyre-plate contact is close to the terminal section of the tyre-ground contact emitter in order to reproduce the real rolling emission (primary source). The tyre and the control system acoustical emitter are anchored to the frame; their position may be adjusted in order to determine the best performances of the active control system. Secondary and primary sources are acoustically coupled because of the vicinity between outlet mouth and tyre-plate contact emitter; thus modification of primary source radiation impedance may be achieved. During laboratory experiences a common microphone is used as the error microphone; it is placed into the space which separates acoustical emitter mouth and tyre-ground contact emitter terminal section.

4-PERFORMANCES ANALYSIS

Electrical equivalent circuit of the active control acoustical emitter (see Fig.4) is modelled as follows. The RLC parallel circuit is associated with the resonant box the loudspeaker is installed in. The RLC series circuit is associated to the mobile air mass contained in the holes which divide rear loudspeaker air volume and propagation duct. The voltage generator E_g represents the loudspeaker supplying electrical signal. E_g is connected to the loudspeaker internal resistance R_g and to the electric resistance of the mobile coil R_e . The propagation duct is modelled by an acoustical cavity connected to a variable section duct. The terminal section of the acoustical emitter is modelled with the air resistance R_a . Such a method has been applied for finding the experimental facility equivalent electrical model whose representation and description is omitted because of brevity. Active control acoustical emitter transfer function is sketched in Fig.5. Experimental facility transfer function has also been found.

5-CONCLUSIONS

An original experimental facility for rolling noise active control system has been realized at Acoustic Laboratory of the University of Perugia. The facility allows to calibrate and to optimize rolling noise active control system on steady condition. The transfer functions of the experimental facility and active control system acoustical emitter have been calculated by means of electrical equivalent circuit method. The active control system acoustical emitter transfer functions may be used to synthesize an electrical filter which compensates the acoustical distortions introduced by the emitter itself. Such a filter may be implemented into the control unit signal processing algorithm. In the same way, a filter may be synthesized by the experimental facility transfer function; such a filter may be conveniently used to improve the fidelity of the recorded rolling noise reproduction.

4-REFERENCES

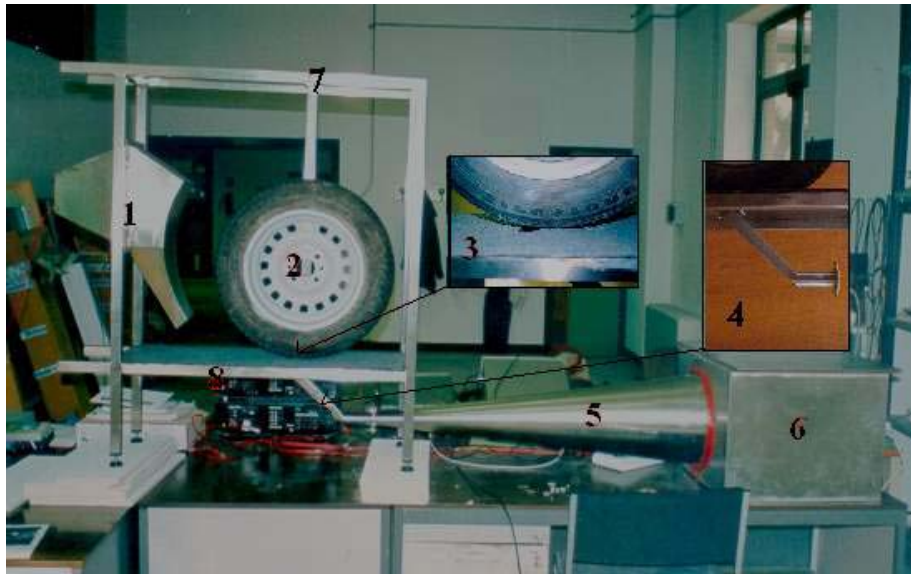

Legend

1. active Control system acoustical emitter;
2. tyre;
3. tyre-ground contact
4. tyre-ground contact emitter
5. acoustical impedance adaptation duct
6. resonant box containing the power loudspeaker
7. adjustable frame
8. flat plate covered with asphalt like film.

- (1) F.Cotana, M.Felli: Congegno Electroacustico per la Riduzione del Rumore prodotto dal Rotolamento di pneumatici sulla pavimentazione stradale e di ruote ferrate sui binari, Ministero dell'Industria del Commercio e dell'Artigianato, Brevetto

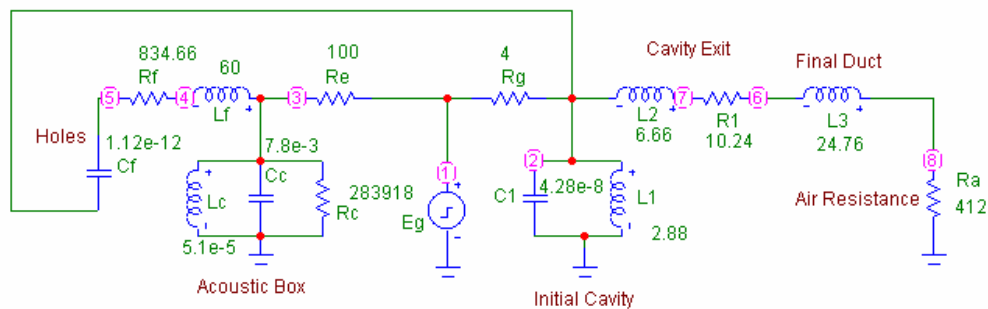

n.01297959, 20/12/1999.

- (2) F. Cotana, C. Buratti: Indagine sperimentale sul rumore stradale da rotolamento, 27° Congresso Nazionale AIA, Genova 26-28 maggio 1999.
- (3) F. Cotana, F. Rossi, L. Santarpia: Riduzione dell'impatto ambientale nei trasporti: costruzione di un dispositivo per il controllo attivo del rumore allo scarico, 49° Congresso Nazionale ATI, Perugia 26-30 settembre 1994.
- (4) G. J. Kim et Al: Identification of the airborne component of tyre-induced vehicle interior noise, Applied Acoustics, Vol. 51, n. 2, pp. 141-156, 1997.

Fig. 3: Experimental facility for rolling noise active control system

Fig.4: Electrical equivalent circuit of rolling noise active control system acoustical emitter.

Fig.5: Transfer function of rolling noise active control system acoustical emitter.

